

PiiGAB

PiiGAB M-Bus 810



Description User Manual

www.PiiGAB.se

ETHERNET / M-BUS GATEWAY 810

Description

User Manual



Copyright © PiiGAB Process Information i Göteborg AB
Anders Carlssons gata 7, S-417 55 Göteborg, Sweden
Phone +46 (0)31 55 99 77

All rights reserved.

PiiGAB are registered trademark of Processinformation i Göteborg AB.
Microsoft, Windows, Windows NT, Windows 2000, Windows XP and Windows Server 2003
are either trademarks or registered trademarks of Microsoft Cooperation in the United States
and other countries. All other trademarks are the property of their respective owners.

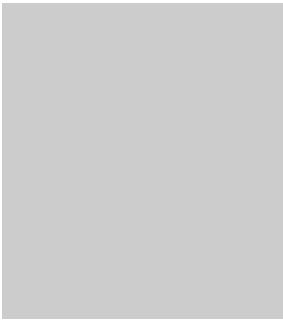

Contents

- 1 GENERAL 4**
 - 1.1 ABOUT THIS MANUAL 4
 - 1.2 FUNCTION OVERVIEW 4
 - 1.3 BENEFITS AND POSSIBILITIES 4
- 2 TECHNICAL STRUCTURE 5**
 - 2.1 CONNECTIONS 5
 - 2.2 INDICATIONS 6
 - 2.3 TECHNICAL SPECIFICATIONS 6
 - 2.4 SUPPLY VOLTAGE 6
 - 2.5 M-BUS SPECIFICATIONS 7
 - 2.6 ETHERNET CONNECTION 7
 - 2.7 SERIAL CONNECTION (RS232) 7
 - 2.8 DRAWINGS 8
 - 2.9 COMMUNICATION CABLES 9
 - 2.9.1 Pin connection for module contact RJ12 9
 - 2.9.2 Adapter 1: Serial to M-Bus 10
 - 2.9.3 Adapter 2: Configuration 10
 - 2.9.4 Adapter 3: Ethernet to serial port 10
 - 2.9.5 Adapter 4 and 5: Spy 11
- 3 GET STARTED STEP BY STEP 12**
 - 3.1 NECESSARY INFORMATION 12
 - 3.1.1 Hardware address 12
 - 3.1.2 IP Address 12
 - 3.1.3 TCP/UDP 12
 - 3.1.4 Port number 12
 - 3.2 USING M-BUS WIZARD 13
 - 3.3 ADJUSTMENTS FOR TCP/UDP AND PORT NUMBER 13
 - 3.4 COMMUNICATION TOWARD METERS 14
 - 3.4.1 The right communication speed 14
 - 3.4.2 Adjusting the meter's communication speed 14
 - 3.4.3 Manufacturer specific configuration software 14
 - 3.4.4 Important parameter adjustments 14
- 4 M-BUS WIZARD 15**
 - 4.1 STARTING M-BUS WIZARD 15
 - 4.2 FINDING THE GATEWAY AND CHANGE IP ADDRESS 16
 - 4.3 COMMUNICATION TEST (PING) 19
 - 4.4 CONFIGURATION PARAMETERS 20
 - 4.5 METER SETTINGS 23
- 5 OTHER CONFIGURATION METHODS 28**
 - 5.1 USING THE SERIAL PORT 28
 - 5.2 USING TELNET 29

6	SERIAL COMMUNICATION CABLES.....	31
6.1	GENERAL INFORMATION.....	31
6.2	SERIAL TO M-BUS.....	31
6.3	CONFIGURATION.....	32
6.4	ETHERNET TO SERIAL.....	32
6.5	SPY.....	32
7	DEVICE INSTALLER	34
8	COM PORT REDIRECTOR	36
8.1	INTRODUCTION TO COM PORT REDIRECTOR.....	36
8.1.1	<i>Overview.....</i>	36
8.1.2	<i>Non-Redirected Connection vs. Redirected Connections.....</i>	37
8.2	INSTALLING COM PORT REDIRECTOR.....	38
8.3	CONFIGURATION.....	43
8.3.1	<i>General Configuration Guidelines.....</i>	43
8.3.2	<i>General Com Port Redirector Usage Guidelines.....</i>	43
8.3.3	<i>Redirector Configuration.....</i>	44
8.3.4	<i>Verifying Connectivity with the gateway.....</i>	46
9	APPENDIX	47
9.1	CONTACTS.....	47

1 General

1.1 About this manual

This manual will hopefully give you the guidance you need to connect the Ethernet/ 810 M-Bus gateway to your network. This manual also describes how the software M-Bus Wizard, Device Installer, and Com Port Redirector works. These software programs are on the attached CD or you can download them from our WebPages.

1.2 Function overview

The PiiGAB 810 gateway is working like an interface between Ethernet and the M-Bus wire. The gateway is transparent, which means that the questions asked through the Ethernet are being forwarded onto the electrical M-Bus interface. The same applies to the answers from the meters that are being sent over the Ethernet to the superior system. The gateway also works as a pure serial M-Bus gateway.

1.3 Benefits and possibilities

- The gateway can be used on either 10 or 100 Mbit network.
- The possibility to choose between TCP/IP or UDP/IP
- SNMP for network surveillance
- The gateway can be used with a fixed IP or a dynamic IP via DHCP
- It is totally independent from the operating system, which means it can be used both by Linux and Windows.
- If there is a need for high safety in the network the data traffic can be encrypted with up to a total of 256 bites. This is an extra, which you need to request before ordering.
- Can work as TCP client or server
- The possibility to set a password to prevent unauthorized to change the configuration.

2 Technical structure

The interface of the gateway consists of an Ethernet connection, a serial port, four parallel outputs for the M-Bus connections, and a connection for voltage supply.

There is also a possibility to connect a safety earth when the gateway is being used in environments with a lot of disturbance.

On the front of the gateway there are three diode lamps that are indicating the voltage feed, transmit and response of the M-Bus messages. The voltage diode lamp has different behaviors depending on normal running, short circuit, or overload of the M-Bus loop.

2.1 Connections

In the table below you will find information about how to connect to the 12 pins screw terminal.

Table 2-1. Connections

Connection	Term	Description
1	AC/DC+	The gateway is powered by 24V AC or DC. When DC is used connect the positive + cable to connection 1.
2	AC/DC-	When DC is used connect the negative – cable to connection 2.
3	GND	This connection is used when it is problem with disturbances or interferences at the main power line or the M-Bus loop.
4	--	Not used
5	M-Bus	Connection for M-Bus loop 1
6	M-Bus	Connection for M-Bus loop 1
7	M-Bus	Connection for M-Bus loop 2
8	M-Bus	Connection for M-Bus loop 2
9	M-Bus	Connection for M-Bus loop 3
10	M-Bus	Connection for M-Bus loop 3
11	M-Bus	Connection for M-Bus loop 4
12	M-Bus	Connection for M-Bus loop 4

2.2 Indications

There are three diode lamps on the gateway Pwr, Tx, and Rx.

The Pwr diode lamp provides three different types of information. The red power diode normally has a firm red light. If the power diode flashes at a 5 Hz frequency there has been a short circuit on the M-Bus loop. If it flashes at a lower frequency (1 Hz) the loop has been overloaded. The M-Bus gateway is available as either a 20 or a 60 device master. If those numbers are exceeded there will be a lower frequency flash.

The Tx diode lamp has a flashing green light when the gateway is sending out a question onto the M-Bus loop.

The Rx diode lamp has a flashing green light when the gateway receives an answer from one of the meters connected to the M-Bus loop.

2.3 Technical specifications

Table 2-2. Technical specifications

Connection	Description
Supply voltage	24V AC/DC (local supply)
Rated Current	350mA (24V AC, 60 slaves) 250mA (24V AC, 5 and 20 slaves)
Operating temperature	-20°C till +55°C
Storage temperature	-35°C till +70°C
Dimension	WxHxD 70x86x57
Weight	120 g
Protection type	IP 20
Housing material	Lexan 940 / VO 1550
M-Bus	EN 1434-3
Emission	EN 50 022 class B radiation EN 50 022 class B conducted
Immission	EN 61 000-4-2 EN 61 000-4-6 ENV 50 140 ENV 50 240 IEC 1000-4-2

2.4 Supply voltage

The gateway should be supplied from a local 24 AC/DC transformer. If using a central 24 DC power supply you should mount a DC/DC converter between the gateway and the central power.

2.5 M-Bus specifications

Table 2-3. M-Bus specifications

Connection	Description
Communication speed	300 – 9600 bps (Normal 300 or 2400 bps)
Voltage ground level ("1")	40V (±1V)
Voltage zero level ("0")	28V (±1V)
Short circuit level	140mA
Internal resistance	<100 Ohm
Number of units	20 or 60 (each unit maximum load 1.5mA)

2.6 Ethernet connection

Communication speed: 300 – 230000bps

Connector type: 8 Position Modular (RJ45)

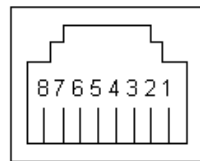

Female socket

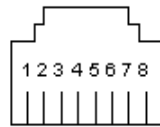

Male plug

2.7 Serial connection (RS232)

Communication speed: 300 – 38400bps

Connector type: 6 Position Modular (RJ12)

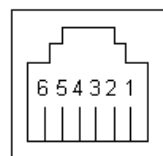

Female socket

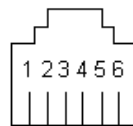

Male plug

2.8 Drawings

Figure 2-1. Cabinet

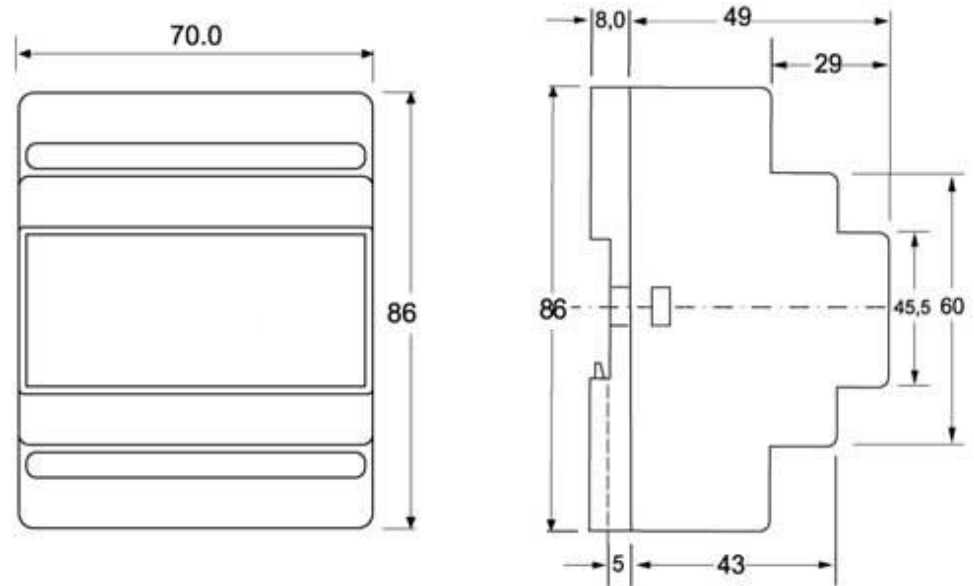

2.9 Communication cables

The serial port can be used in four different ways with the help of five different adapters.

The following four ways are possible

- Serial to M-Bus
- Configuration of the gateway
- Ethernet to the serial port
- Spy possibility

2.9.1 Pin connection for module contact RJ12

In figure 2-2 the pin location in the female module contact RJ12 in the gateway are shown

Figure 2-2 Pin description RJ12 socket

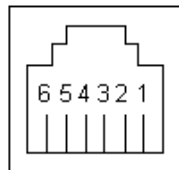

Female socket

Table 2-4. Connections in module contact RJ12

Pin Number	Direction	Comment
1	GND	Ground
2	Rx	M-Bus→Serial
3	Rx	Serial→Ethernet
4	Tx	Ethernet→Serial
5	Tx	Serial→M-Bus
6	N/A	Not used

The following section describes the different adapters that can be connected to the gateway. A more detailed description including examples can be found in chapter 6.

2.9.2 Adapter 1: Serial to M-Bus

To communicate through the serial port directly to M-Bus adapter 1 is used.

Connect the adapter to the COM port on the computer and the straight module cable between the adapter and the RJ-12 contact on the gateway.

Table 2-5. Connection for adapter 1

9-pin DSUB/F	RJ12/F
Pin 2 (RxD)	Pin 2
Pin 3 (TxD)	Pin 5
Pin 5 (GND)	Pin 1

2.9.3 Adapter 2: Configuration

When configuration is to be made via the serial port adapter 2 is used.

Connect the adapter to the COM port on the computer and the straight module cable between the adapter and the RJ-12 contact on the gateway.

Table 2-6. Connection for adapter 2

9-pin DSUB/F	RJ12/F
Pin 2 (RxD)	Pin 3
Pin 3 (TxD)	Pin 4
Pin 5 (GND)	Pin 1

2.9.4 Adapter 3: Ethernet to serial port

If the gateway is being used as an Ethernet/RS232 gateway adapter 3 is used. Observe that hardware handshaking can't be connected.

Connect the adapter to the unit, which communication will be established and the straight module cable between the adapter and the RJ-12 contact on the gateway.

Table 2-7. Connection for adapter 3

9-pin DSUB/M	RJ12/F
Pin 2 (RxD)	Pin 4
Pin 3 (TxD)	Pin 3
Pin 5 (GND)	Pin 1

2.9.5 Adapter 4 and 5: Spy

All the traffic that are being sent and received on the M-Bus port are mirrored to the serial port. This results in that you can connect a serial analyzer or monitoring software. To be able to read what is being written and read two communication ports are demanded on your computer.

Through using adapter 4 and 5 monitoring can be done. Adapter 4 is used to monitor the question and adapter 5 is used to monitor the answer.

The two adapter's module cables are connected via a branch and onto the gateway's RJ-12 contact.

Table 2-8. Connection for adapter 4 (Ethernet request)

9-pin DSUB/F	RJ12/F
Pin 2 (RxD)	Pin 3
Pin 5 (GND)	Pin 1

Table 2-9. Connection for adapter 5 (M-Bus response)

9-pin DSUB/F	RJ12/F
Pin 2 (RxD)	Pin 2
Pin 5 (GND)	Pin 1

3 Get started step by step

This chapter covers the different steps needed to put the M-Bus 810 gateway into operation.

3.1 Necessary information

The connecting of the supply voltage and the M-Bus loop is made according to table 2.1.

3.1.1 Hardware address

You have to know the unit's hardware address, which is the same as the MAC address. The MAC address can be found on the label on one of the gables of the unit. It has the format 00-20-4a-xx-xx-xx, where xx is a unique number for the unit.

3.1.2 IP Address

Most of the time the gateway needs a unique IP address on your network in order to be connected to the superior software. You can also use the automatic IP address via DHCP if you wish. Contact the system administrator to receive the right IP address with the belonging subnet mask and gateway. The IP address has to be within the allowed area, unique within your network, and it has to be in the same subnet as your PC.

3.1.3 TCP/UDP

To communicate with the superior software you have to choose between TCP or UDP.

We do not recommend that any of PiiGAB's products or products bought from PiiGAB should be made public on the internet. We always recommend that a firewall is used, not following this recommendation will be at your own risk.

3.1.4 Port number

To communicate with the gateway the port number has to be adjusted. The default adjustment in the gateway is 10001 and can almost always be used. Control with the network responsible what port number to use.

3.2 Using M-Bus Wizard

By using the M-Bus Wizard you can set the IP address and all other important parameters to be able to communicate with your M-Bus meter. The M-Bus Wizard is described in chapter 4.

You can search for 810-units in your network through the Wizard. There is usually an IP address positioned on the gateway and if the address is outside the permitted IP address area this will be marked in red. If you still are having trouble finding the gateway on the network you can search and configure the gateway through the MAC address. You cannot find the gateway if it is connected to a sub network.

3.3 Adjustments for TCP/UDP and port number

To adjust the TCP alternatively UDP the M-Bus Wizard is used, and it can be found in chapter 4. Choose "Change Device Parameters" from the main menu and click through to the site where you make your choice. At PiiGAB we recommend usage of UDP if this is supported by the superior software. The reason for this is that the M-Bus driver has complete control over how the questions and answers are being sent.

The adjustment of the port number is made at the same place as the TCP/UDP in the Wizard. The port number has to be the same as in the calling from the superior software in order for contact to be established with the gateway.

3.4 Communication toward meters

3.4.1 The right communication speed

After the right IP address has been established the M-Bus loop's communication speed has to be adjusted. The communication speed adjusted in the Wizard has to match the meters communication speed. Many meters have a communication speed of 300bps at delivery. If there is a possibility to set the meters at 2400bps try to do that in order to increase the communication speed and by that improve the performance.

When communication toward the meters has been established and by that the M-bus loop is connected the right way, you can continue to configure the superior software.

3.4.2 Adjusting the meter's communication speed

In version 1.0 of the M-Bus Wizard you can control the meter on your M-Bus loop directly via the meter's primary address. You can also adjust functions such as communication speed and primary address via your network. Note that some meter makes do not support the possibility to change for example the primary address via a standard M-Bus command.

3.4.3 Manufacturer specific configuration software

If you want to configure the meters via the meter delivery's own software you can do so in most cases over the network via the gateway. They usually have no network support, so they communicate only via the communication port on the computer. By using Comport Redirector, described in chapter 8, you can usually use this software in your network.

3.4.4 Important parameter adjustments

Some issues to keep in mind regarding communication between the meter and the superior software is the time interval between the questions, the number of telegram that can be read by the meter, and what communication speed that has been chosen. Some meters has up to 40 telegrams that can be read at a adjusted transference speed of 300bps, and therefore take along time.

The M-Bus driver for the SCADA program Citect, which has been developed by PiiGAB, is documented with great details regarding how different parameters are being set in programs like NrOfTelegrams, InitRead etc. The document "Citect for Windows, Version 5.xx, 6.xx M-Bus driver, User Information" (Version: 1.01.03.001-1) is available to download at the PiiGAB website.

4 M-Bus Wizard

M-Bus Wizard is a software delivered with the gateway. The software helps you to make required adjustments in the gateway to establish communication etc. It also gives you the opportunity to change address and communication speed on the meters that supports the M-Bus standard, additionally you can see some parts of the communication towards the meter.

4.1 Starting M-Bus Wizard

Copy the zip-file "M-Bus 800 Family Setup Wizard 2.0.1.zip" to the appropriate folder on the computer and open the file. Install the program by double clicking on the Setup files or go via the control panel. After the program has been installed you can start it by choosing the program in the start menu. If the installation has been made with the base settings the program can be found under the PiiGAB folder.

The first time you start the program you have to choose a language. If you later want to change to another language it is also possible.

After the language has been chosen, the introduction picture is presented with a summary of the M-Bus Wizard usage.

Figure 4-1. Welcome Screen



Click "Next" to proceed.

4.2 Finding the gateway and change IP address

Figure 4-2. Select what you wish to do

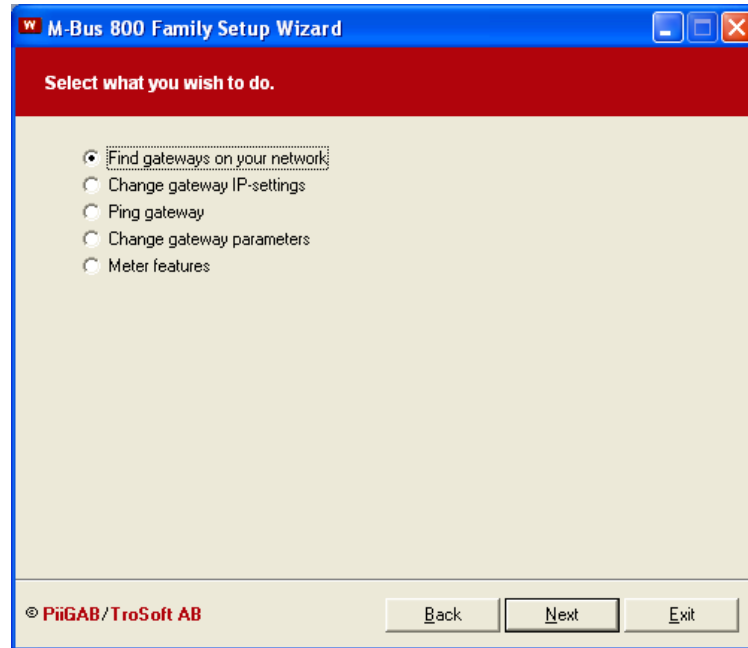

The next page (main menu) shows the different commands that can be made with the M-Bus Wizard. Choose your option and click "Next." If the gateway has not been configured before choose **Change device IP Settings** and click "Next."

Figure 4-3. Change IP settings – select connection method

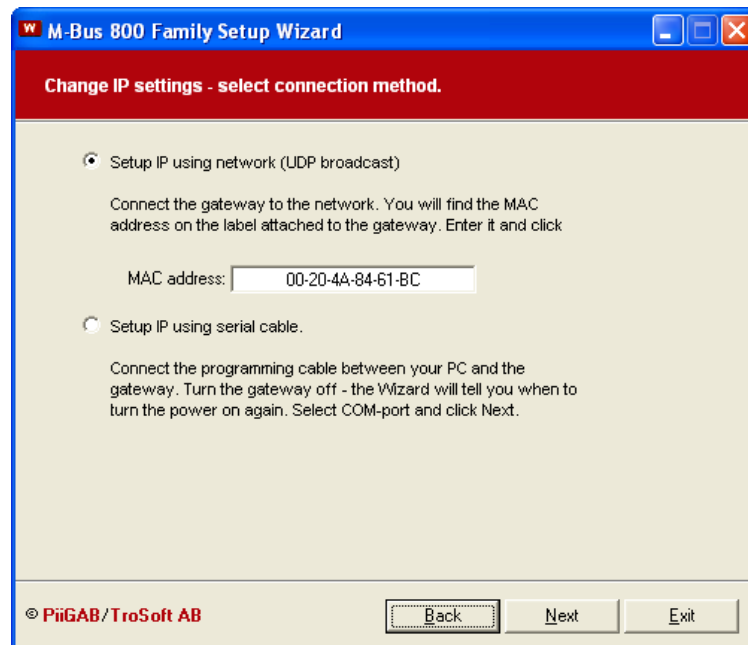

In this picture you are choosing the way you want to communicate to install the IP address. If 810 is connected to the network choose the option on top and with a serial connection pick the lower. In this part we are assuming that the gateway is connected to the network. On the side of the gateway there is a label with the

810M.E.1.14

MAC address, which is filled out according to the picture. Click "Next" after this. If the configuration is made via the serial port use adapter 2, see chapter 2.8.1. Follow the Wizard instructions to configure this way. The difference to configure via the network is that the voltage has to be turned on and off in order for the settings to have an effect.

Figure 4-4. Change IP settings – enter new IP settings

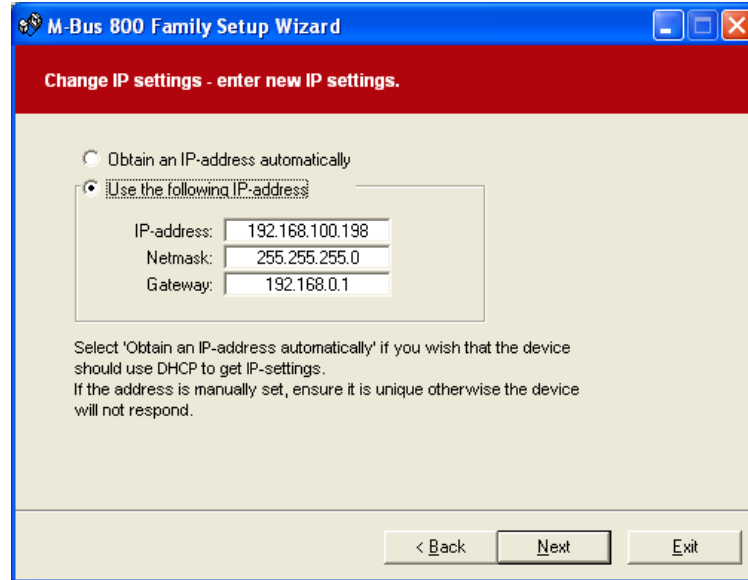

Fill out the fields, IP-address, Netmask, and Gateway. If you are using DHCP choose the upper option otherwise choose the lower. If you are going to use a unique IP address contact the responsible for the network in order to get the correct information. Click on "Next" to continue.

Figure 4-5. Change IP settings – update device



810M.E.1.14

This picture is solely here to inform you about that the next step is to activate the earlier made configuration like IP-address, subnet mask, and gateway address. When you click on "Apply" the configuration starts. When the gateway is updated with the new information click "Next" to continue.

If you already know that the gateway has an IP address that can be found via the network choose **Find Devices** from the main menu as the first step instead. If the unit is found on the network you do not have to provide MAC-number when you are setting the IP address. Sometimes it can be hard to find the gateway and the reason for that can be because it is in a subnet. Contact the network responsible for further information about the network.

Figure 4-6. Outside permitted address area

IP-address	MAC-address	Info
 192.100.100.100	00-20-4A-84-F1-1E	Setup may fail

If the IP address can be found outside the permitted address area, but is possible to reach within the network, this is shown in the Wizard (see above.)

Figure 4-7. Network search complete

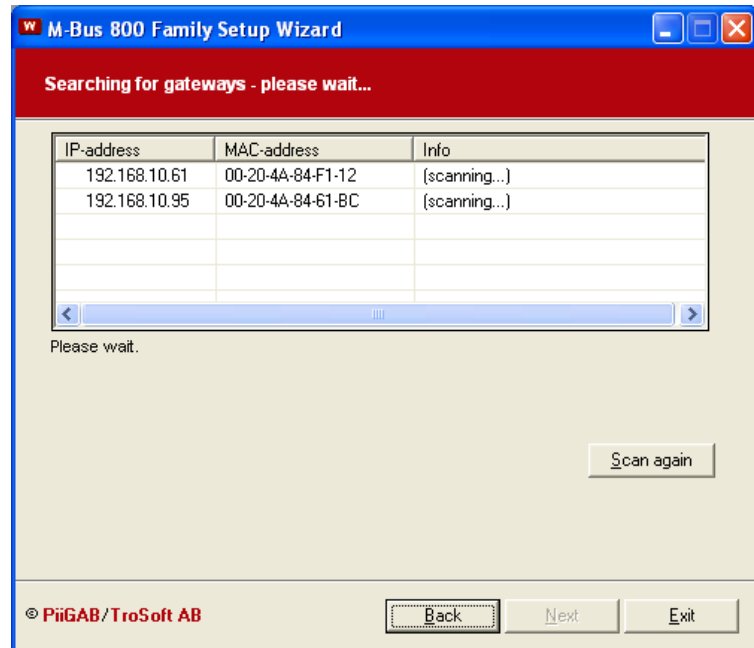

If the gateway can be found within the network you can see it in the above listings. Choose the preferred meter and click "Next" to go to the main menu.

4.3 Communication test (Ping)

Figure 4-8. Ping device

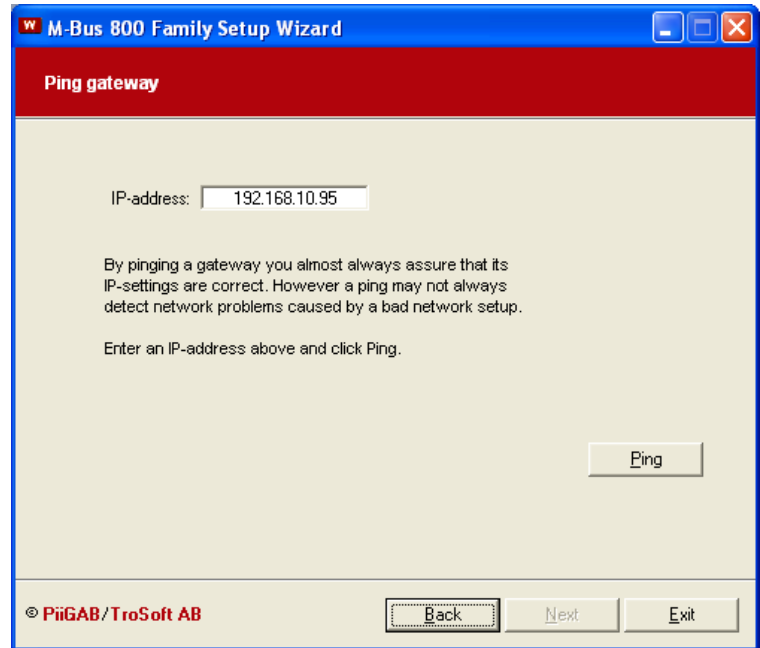

The above picture will be presented to you after choosing **Ping Device** from the main menu. Fill in the IP address on the gateway you want to control and push "Ping". If the earlier steps in the Wizard are made correctly, the chosen IP address will show up on this page.

Figure 4-9. Ping device



If you make contact by using the Ping command the above communication result will show. Push "Next" to continue.

4.4 Configuration parameters

From the next part in the main menu, **Change Device Parameters**, configuration of the gateway can be made. This is done to make necessary adjustments to make the right communication towards the superior system and towards the meters on the M-Bus loop possible.

Figure 4-10. Change device parameters

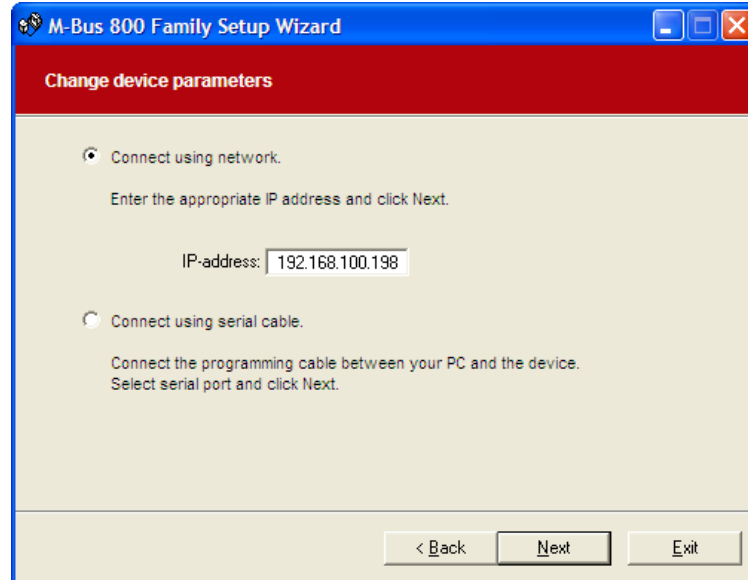

At this point there are two choices, to configure the gateway via the network, or via the serial-port on the gateway. If the serial port is chosen adapter 2 is used, see chapter 2.8.1. Follow the Wizard instructions to configure via the serial-port. The difference from configure via the network is that you have to turn the voltage off and on to get to the installations.

Figure 4-11. Change device parameters

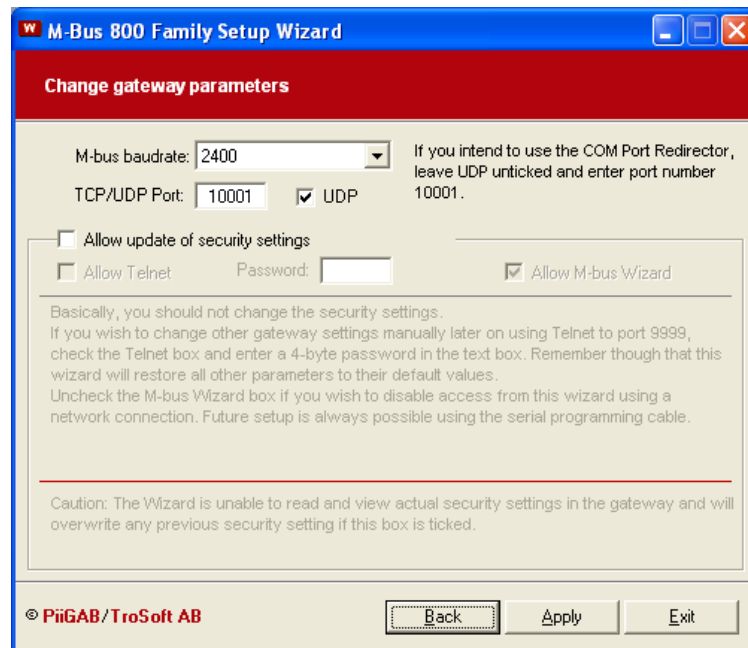

810M.E.1.14

If configuration via the network is chosen, the upper picture will show up and you can choose the communication speed for the gateway, and what port name and if UDP or TCP will be used.

There is also a possibility to configure the gateway so that there is a password needed to change the installations, see the picture bellow. There are other safety installations that can be made, but it has to be done via the Device Installer or with the Hyper Terminal and serial connection. See the document "DeviceInstaller_UG_900-310.pdf"¹ for further installation information.

Figure 4-12. Change device parameters

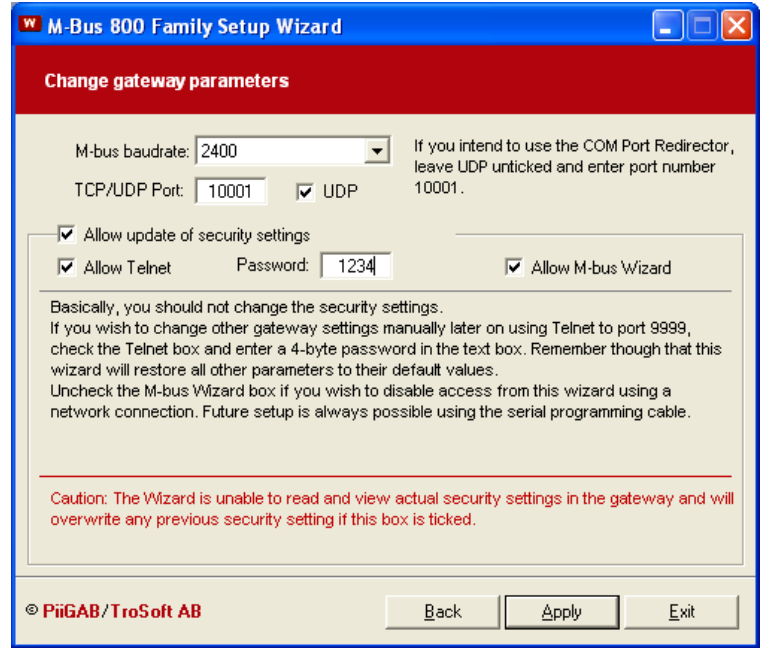

If serial communication is chosen the following picture will show.

¹ This document can be found at the CD delivered together with the gateway.

Figure 4-13. Change device parameters

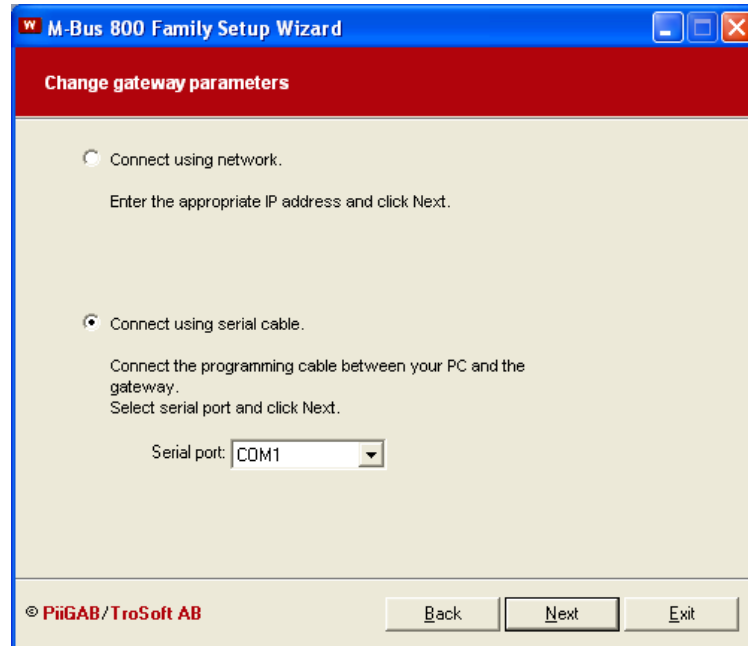

After the port has been chosen click "Next" and follow the picture instructions. The same configuration picture will be shown as the one for configuration over the network.

4.5 Meter settings

When the previous steps are done the gateway is ready to communicate out onto the M-Bus loop. To get to this part of the Wizard choose **Meter feature**.

By this choice a "SND_NKE" question is sent to test the communication and to set the meter at zero to be able to read the first telegram.

Figure 4-14. Initialize meter

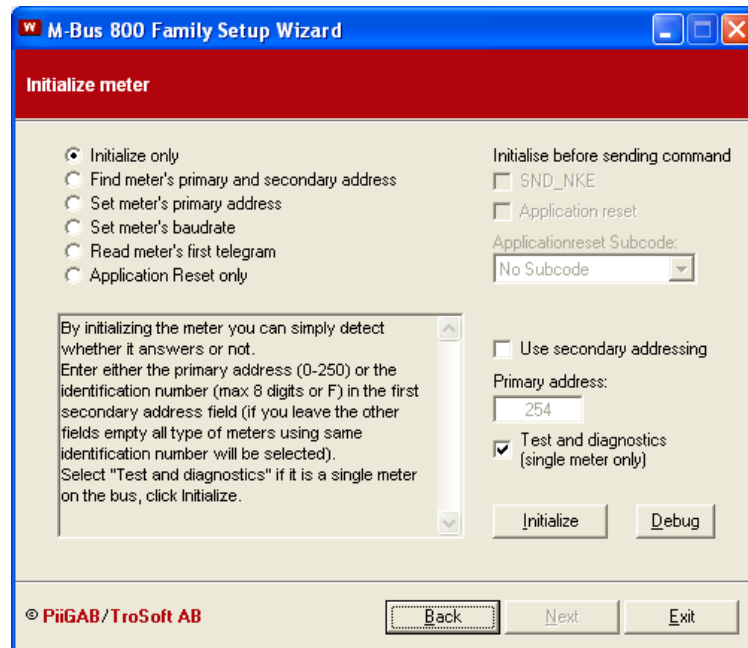
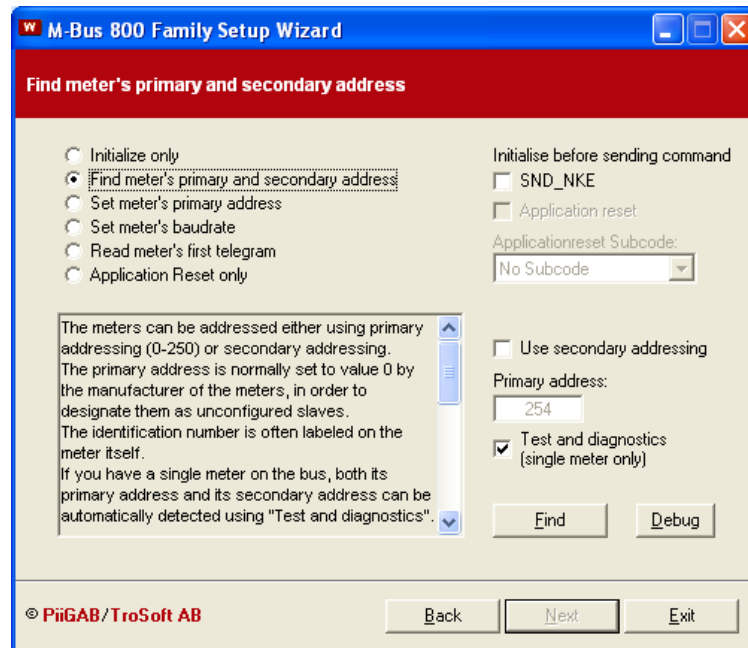

Figure 4-15. Find meter's address



By this choice you get information about what primary and secondary address the meter has. If you do not know the meter's address choose "Test and diagnostics"

810M.E.1.14

and you will get the information both about primary and secondary address. The "Test and diagnostics" function can only be used if one meter is connected to the M-Bus loop. Some meters do not support secondary addresses, but the information about the secondary address can still be read from the meter.

Figure 4-16. Find meter's address

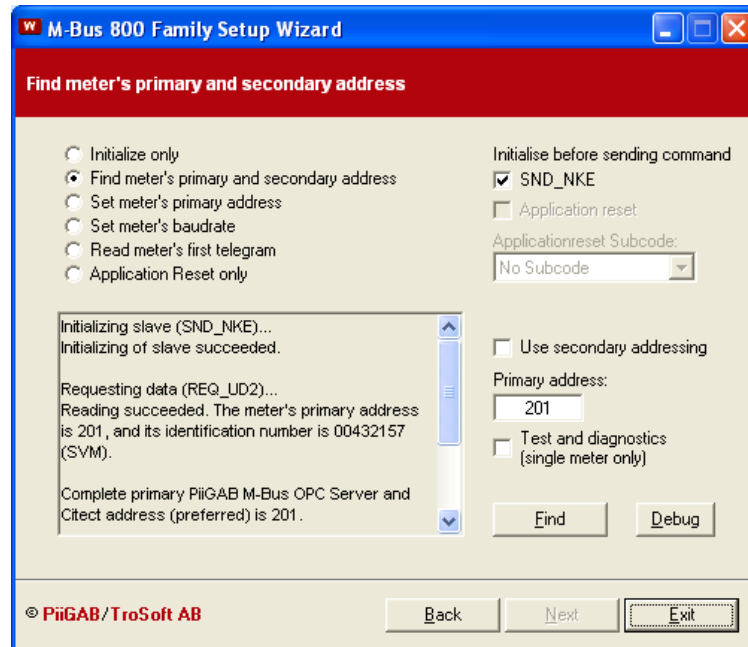

This is the way it can look when the meter is answering.

Figure 4-17. Set meter's primary address

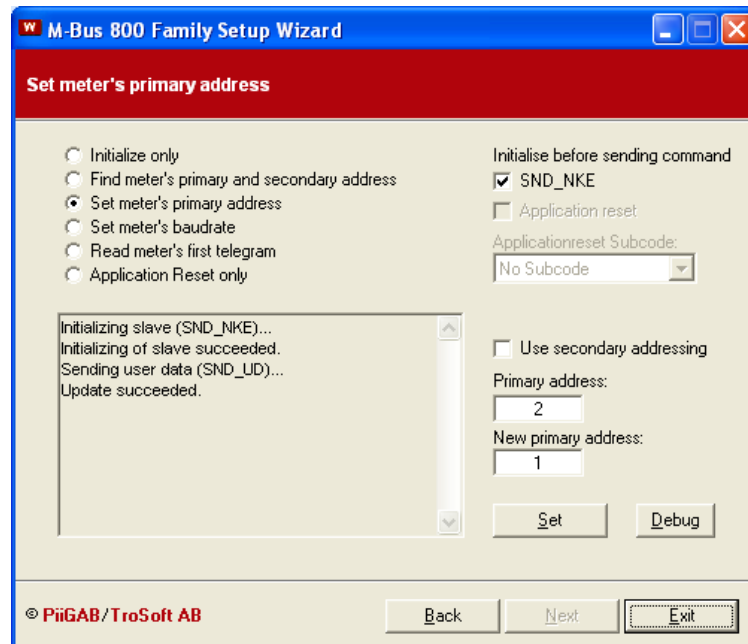

There is also a possibility to change the meter's primary address. Some meter manufacturers do not support the possibility to change the primary address on the

meter with an M-Bus command. Check with the manufacture about what the case with your meter is.

Figure 4-18. Set meter's baurate

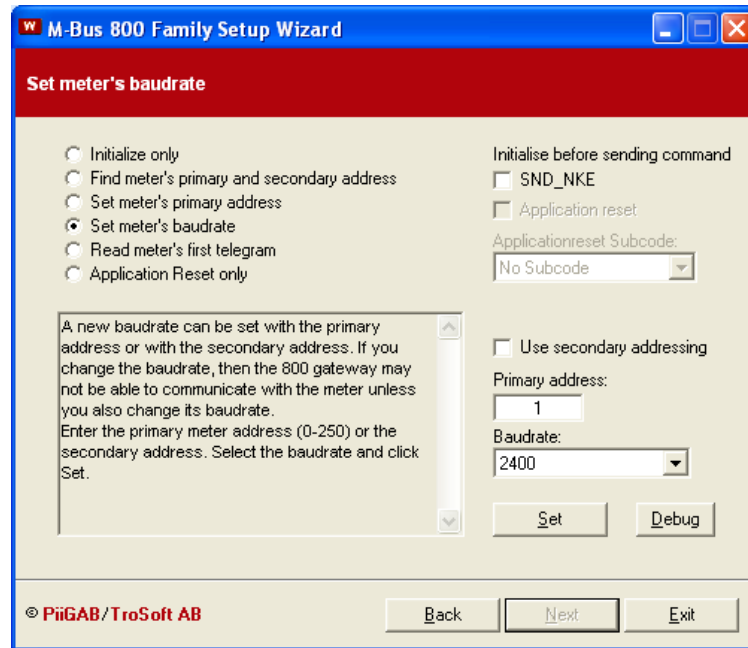

The communication speed can be changed by this choice. When the meter is being updated you will receive information that the updating succeeded. Some meters answer faster than the M-Bus standard; therefore occasionally you do not get the information although the meter has been updated. If this is the case, do a test on the communication speed to make sure the change has been made. It is very important to read the communication speed after it has been changed, because some meters change back the communication speed after a while if the reading of the new speed has not been made.

Figure 4-19. Read meter's first data telegram

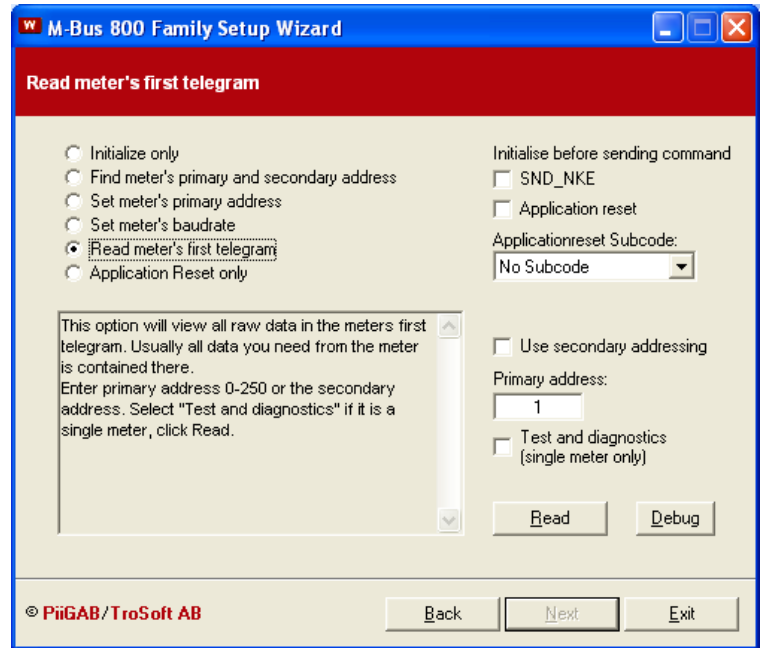

The first telegram can be read out by this choice.

Figure 4-20. Read meter's first data telegram

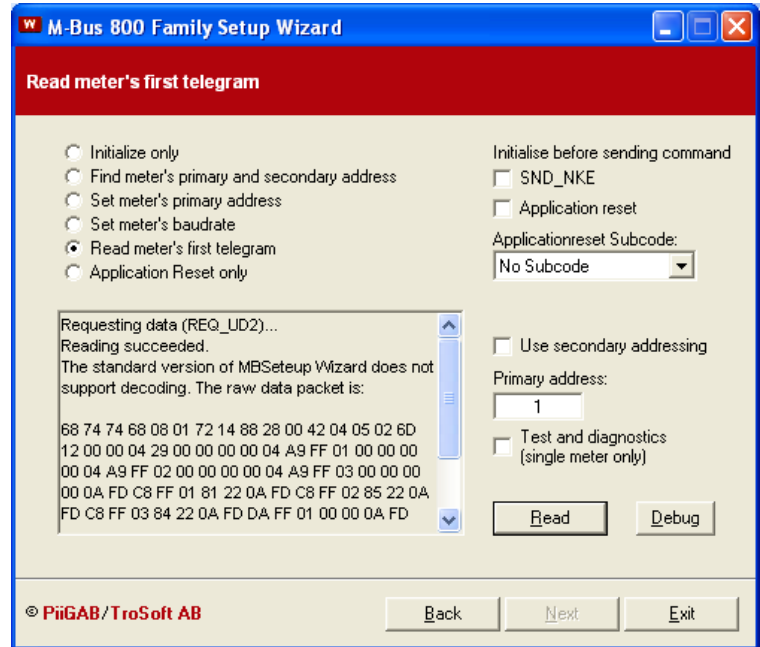

This is the way it can look when the meter is answering.

Figure 4-21. Application Reset only

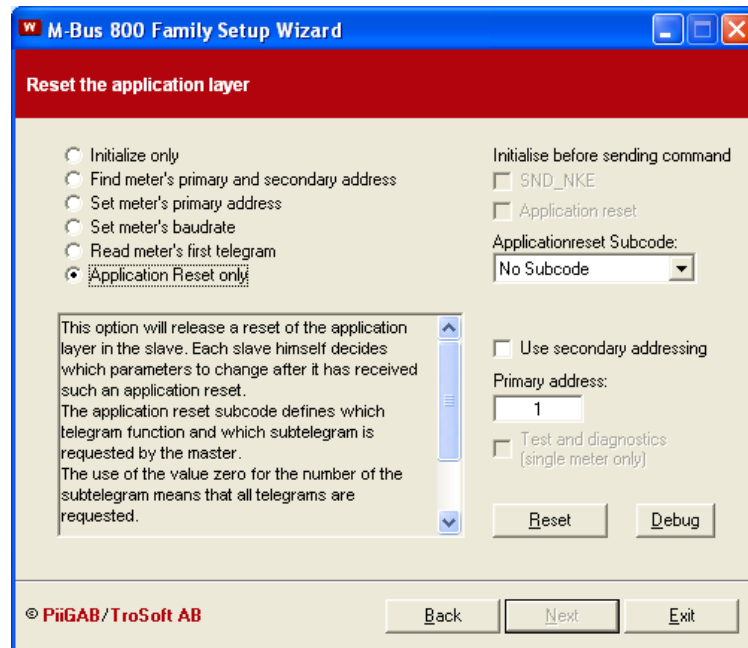

Some meters need an application reset instead or in combination with SND_NKE to reset the meter to be able to read the first telegram. In some cases the meter need a subcode together with the application reset which also is possible to choose.

5 Other configuration methods

There are many different ways to configure the gateway, so it can communicate over the network. The easiest and most effective way is to use the M-Bus Wizard described in chapter 4. The other two methods presented are via the serial communication port or over Telnet.

5.1 Using the serial port

Before the configuration can be started via the serial port you have to initiate the communication:

1. Connect the serial port to the gateway's serial-port with adapter 2.
2. Start a terminal program like HyperTerminal to the serial-port that the gateway is connected to. The base installation should be 9600 baud, 8 bites, no parity, 1 stop bit and no flow control.
3. To get into Setup Mode you have to set the unit at zero by breaking the voltage and turn it back on. Now a self test will start. **You have one second** to write three lower case x signs (**xxx.**)

Observation: The easiest way to activate the Setup Mode is to hold down the x key as the unit is being set at zero.

4. The screen will now show the same information as if you would use a Telnet connection. To continue see chapter 5.2 "Using Telnet."

5.2 Using Telnet

To configure a unit over the network via Telnet you have to first create a connection to port 9999.

Figure 5-1. Example Telnet

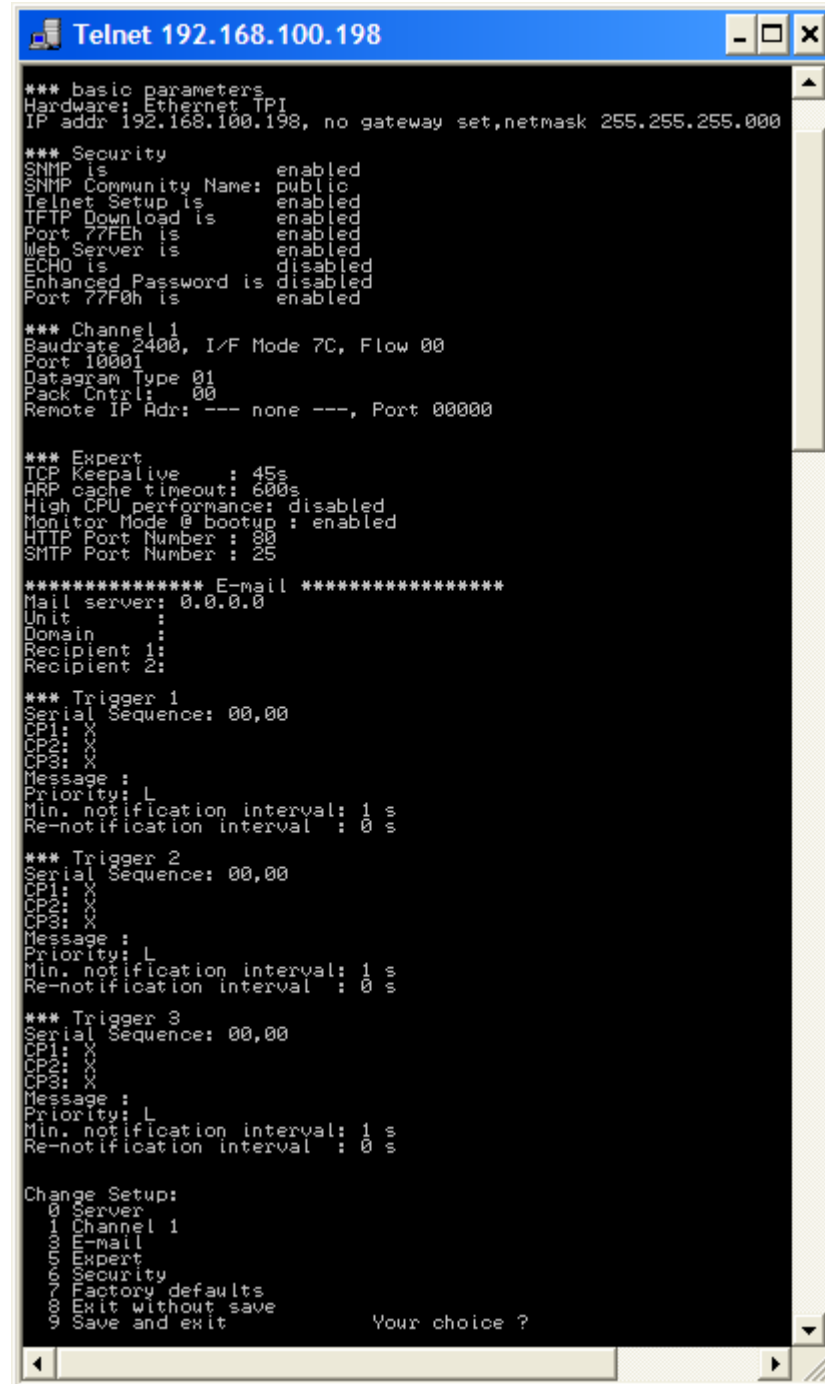

The necessary settings to do if you are using Telnet to get the communication to work are:

Start by doing a Factory default, by that you will know that all the base settings are correct. Write the IP address, netmask, gateway with the Server choice after that.

Then the communication speed, communication parameters (8, Even,1), flow control, port number, connection mode (TCP/UDP) and datagram has to be set. These settings are done in Channel 1. There are other settings under this choice, but these do not have to be made.

Communications speed	300, 2400 or 9600
Communications parameters	7C (8, Even, 1)
Flow control	00 (None)
Port number	10001 (Contact the person who is responsible for the network to get correct information.)
Connection mode	CC (UDP), C0 (TCP)
Datagram Type when UDP	01

If you want to make more adjustments please look in the original documentation XPort_UG_900-270.pdf².

² This document can be found at the CD delivered together with the gateway.

6 Serial communication cables

6.1 General Information

The serial connection on the gateway consists of 6 positions female module (often called RJ12.) Since there are many different areas of usage for the serial connection, we can offer a number of adapters from 9-pin DSUB to RJ12. It is important that the right module cable is used between the adapter and the RJ12 connector on the gateway. There are both a straight and a crossing cable on the market. The gateway needs a **direct cable**.

To determine whether you have a direct or a crossed cable you should hold both of the RJ12 connectors next to each other with the contacts facing yourself. If the colors are in the same order on both contacts you have a **direct cable**. If the colors are arranged in opposite order your cable are crossed.

The adapters are connected to the communication port on the computer. A straight cable is used between the adapter and the gateway. When the spying is done both regarding the answer and the question an additional branch connection is used for the module cable.

6.2 Serial to M-Bus

To communicate via the serial outlet directly to M-Bus adapter 1 is used.

Connect the adapter to the COM port and the straight module cable between the adapter and the gateway's RJ-12 contact.

With this connection the 810 gateway becomes a serial (RS232) to M-Bus converter. This function is for debugging and control of the communication onto the M-Bus loop.

Examples of usage:

- At start-up on the M-Bus loop you can with the help of a laptop verify that you have contact with the different meters before you connect yourself to the network.
- If you do not have the network available for all the meters you can use a GPRS modem with an IP stack. Let the modem's RS232 output go via the gateway. When the network has been built out you can connect it to the network port on the gateway instead.
- You can also use the gateway as a pure serial to the M-Bus converter of course.

6.3 Configuration

When configuration is made via the serial-port adapter 2 is used.

Connect the adapter to the COM port and the straight module cable between the adapter and the gateway's RJ-12 contact.

The Ethernet connection is being configured without connecting the network with this type of connection.

Example of usage:

- You have chosen to protect the gateway to prevent unauthorized to affect the internal settings. With some settings you have to choose this way to be able to make configuration changes yourself like, baudrate, port number, IP address etc.
- The gateway has been configured before over the existing network and is in full usage. During a service occasion you want to change the baudrate for the gateway, because adaptation is being made of a newly installed meter, which is using a different baudrate than the earlier setting. This can be preformed on scene with adapter 2 without that the technical staff has to connect themselves via the network.

6.4 Ethernet to serial

If the gateway is being used as a Ethernet/RS232 gateway adapter 3 is used.

Connect the adapter with the equipment that you want to establish communication with. Use the straight module cable between the adapter and the gateway's RJ-12 contact.

When this connection is used the 810 gateway is like a gateway between Ethernet and RS232 (port-server). This makes it possible to connect other equipment that is using RS232 communication. Observe that the hardware handshaking signals are not connected.

Example of usage:

- You want to connect a meter that only supports the electrical interface for RS232 and not the one for M-Bus. Although the protocol is still M-Bus.
- You want to connect other types of meters, plc, or remote units over the net as a RS232 connection. Since the gateway is protocol transparent you can use any protocol you want like for example comli, modbus etc.

6.5 Spy

All traffic being send or received on the M-Bus port are mirrored to the serial port. This means that different types of programs can be connected for monitoring. To be able to both write and read you need two communication ports on your computer.

Through the help of adapter 4 and 5 you can monitor this. Adapter 4 is used to monitor the question and adapter 5 is used to monitor the answer.

This function is of great usage when you want to analyze answers from different meters. Since the entire question and the entire answer from the meter is being reflected all the data pieces can be analyzed.

Example of usage:

- You have a suspicion that the information shown on the superior system is false. By following the transported traffic through the gateway a complete analysis can be done of the M-Bus traffic.
- You have given someone the assignment to do the reading regularly at a set frequency. By monitoring and/or logging the traffic a verification of the done readings can be made.

Below is shown how the traffic can look like with a Serial analyzer

Figure 6-1 Example of serial analyzer from Fifo electronics

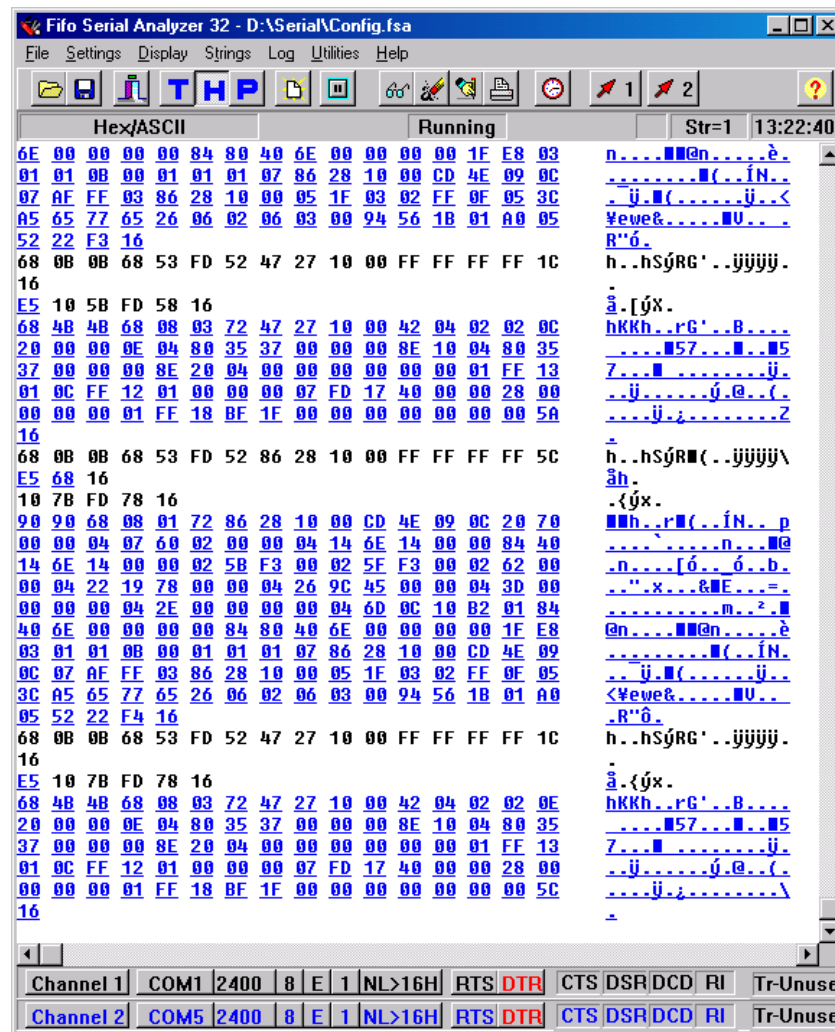

7 Device Installer

The software, Device Installer, is also delivered with the gateway and is there to help you make advanced settings in the Ethernet part of the gateway. To make base changes in the Ethernet part we recommend you to use the M-Bus Wizard, since the M-Bus Wizard is made to simply set up the M-Bus communication.

Although, if you want to use the Device Installer, we refer you to the help in the software and to the enclosed document for the Device Installer, DeviceInstaller_UG_900-310.pdf³.

You need to keep the following settings to use the M-Bus protocol in mind when the Device Installer is used:

- The correct communication speed (300bps, 2400bps alt 9600bps). Not all meters support 9600bps. Check with your meter manufacturer what communication speed to use.
- When the M-Bus protocol is used the Port Settings 8, even, 1 should be made. See below.

Figure 7-1. Port Properties

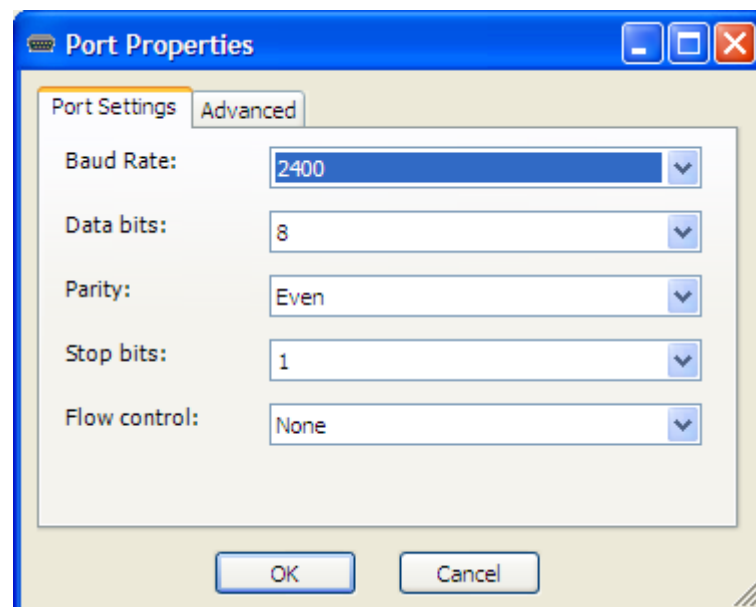

³ This document can be found at the CD delivered together with the gateway.

If UDP is used "Datagram Mode" has to be set to True and "Datagram Type" be set to 01, see the picture below.

Figure 7-2. Port Properties

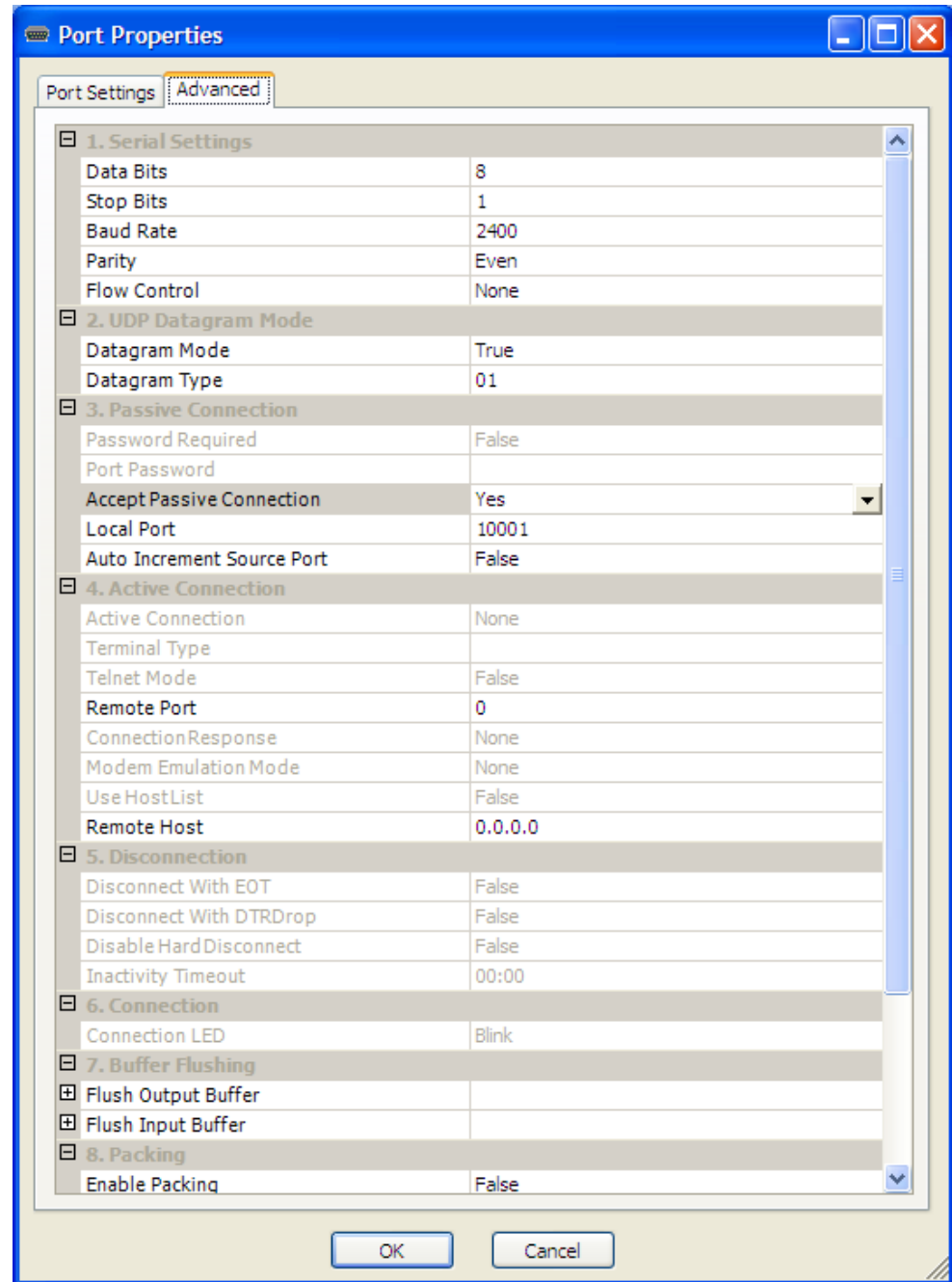

8 Com Port Redirector

8.1 Introduction to Com Port Redirector

8.1.1 Overview

Com Port Redirector is a software utility for network-enabling legacy software applications that do not have network support. Com Port Redirector installs virtual Windows® communication ports. These virtual communication ports are redirected over a network to the M-Bus port of a PiiGAB 810 Gateway.

The communication with the gateway is done in pretty much the same way as when "pure" TCP/IP is used. The main difference is that the software sees the gateway as a normal communication port.

Figure 8-1 Example how Com Port Redirector works when 810 is used

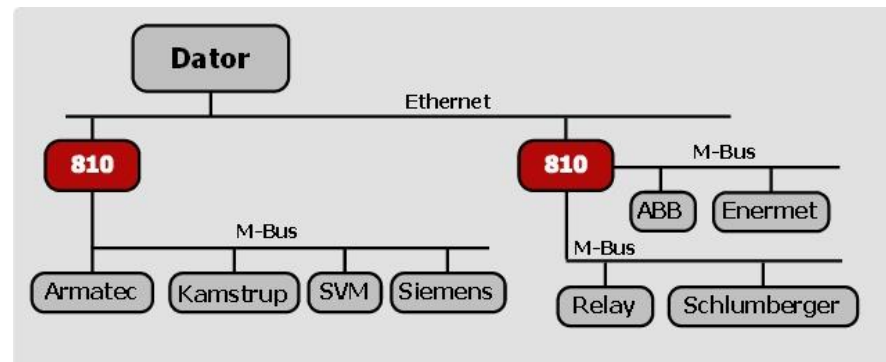

In most cases, legacy software that uses the virtual com ports created with Com Port Redirector encounters no problems and acts as if it were communicating with a physical port. Not all software applications, however, are suited for use with Com Port Redirector.

Serial port software applications are designed for direct communication with the serial device being managed. However, when device servers are used across a network, latency can occur with the connection from the software to the managed 810 gateway. Some software applications have timing constraints for data transmitted and received on com ports. In some cases, a software application will not wait long enough to receive a response from the 810 gateway being managed. As a result, the software assumes the serial device is not responding and times out.

Should increased latency become an issue for a software application, implement a TCP socket connection in the software. If this is not possible, increase the timeout settings in the software to compensate for additional latency.

8.1.2 Non-Redirected Connection vs. Redirected Connections

Most software applications that need to use the Com Port Redirector have been designed to connect directly to the serial device being managed. This connection is achieved using a direct cable connection from a com port on the personal computer (PC) running the software utility to the serial port of the serial device being managed. With this configuration, the PC and the managed serial device reside on an isolated serial network. The traffic passed on the physical media between them is intended for either PC or the serial device. Latency is not an issue in this scenario.

When the same software applications are used with the Com Port Redirector, the applications are no longer directly attached to the serial device being managed. Instead, all traffic between the software application and the serial device is routed as follows:

1. From a virtual com port, the data is stripped out of a serial packet and placed into an IP packet.
2. The serial packet is sent from the virtual com port to a network interface on the PC.
3. Data is transmitted over the network, through switches or routers, to the network interface on a device server.
4. From the network interface on the device server, the data converts from an IP packet back to a serial packet.
5. Once in a serial packet, data is transmitted down the physical media to the serial device.

This process introduces latency. The amount of latency associated with this type of connection is determined by the amount of network latency. The more traffic on the network, the greater the latency between the PC running the software application and the M-Bus gateway.

To address latency, Com Port Redirector provides a **No Net Close** option in the Port Settings dialog box. This option keeps the TCP/IP connection open when the com port is closed, reducing latency.

8.2 Installing Com Port Redirector

Installation Instructions

1. To install Com Port Redirector,
 - If Com Port Redirector is on a CD-ROM, insert the CD-ROM into the computer's CD-ROM drive.
 - If you downloaded Com Port Redirector, double-click the download file.

Either step displays the Redirector- Welcome screen in Figure 8-2.

Figure 8-2 Redirector – Welcome Screen

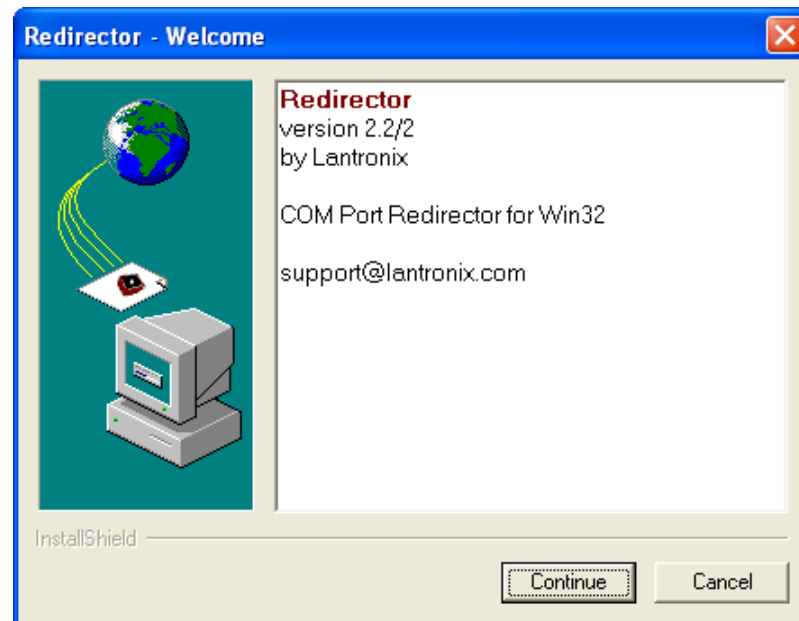

2. Click the **Continue** button. The contents of the file are unpacked and the Welcome screen in Figure 8-3 appears.

Figure 8-3. Welcome Screen

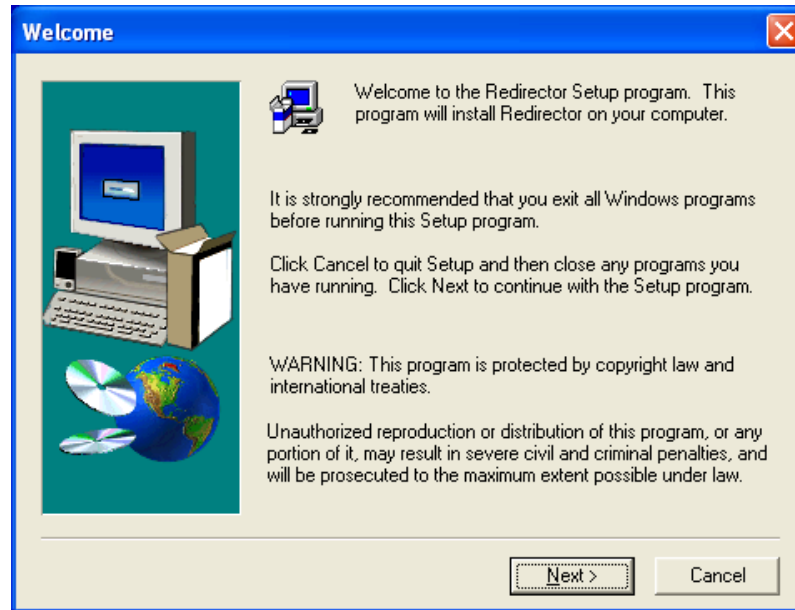

3. Click the **Next** button. The Choose Destination Location dialog box appears (see Figure 8-4).

Figure 8-4. Choose Destination Location Dialog Box

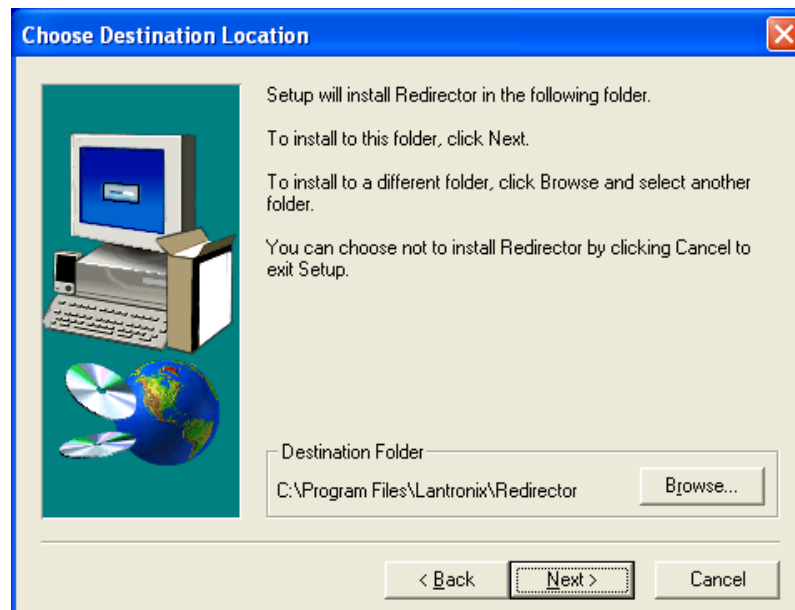

4. The path under **Destination Folder** shows where the Com Port Redirector software will be installed. We recommend the default location. To change this location, click the **Browse** button and select a different location.
5. Click **Next**. The Select Program Folder dialog box appears (see Figure 8-5).

Figure 8-5. Select Program Folder Dialog Box

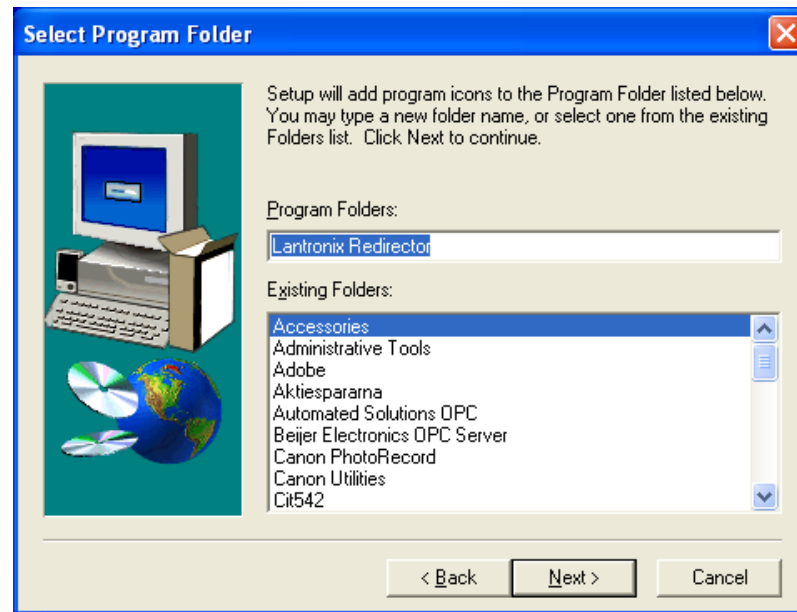

6. The name of the folder that will contain the Com Port Redirector software appears below **Program Folders**. We recommend the default folder name. To change this name, type a new name in the **Program Folders** field.
7. Click **Next**. The program is installed. After the installation, the Setup Complete dialog box appears (see Figure 8-6).

Figure 8-6. Setup Complete Dialog Box

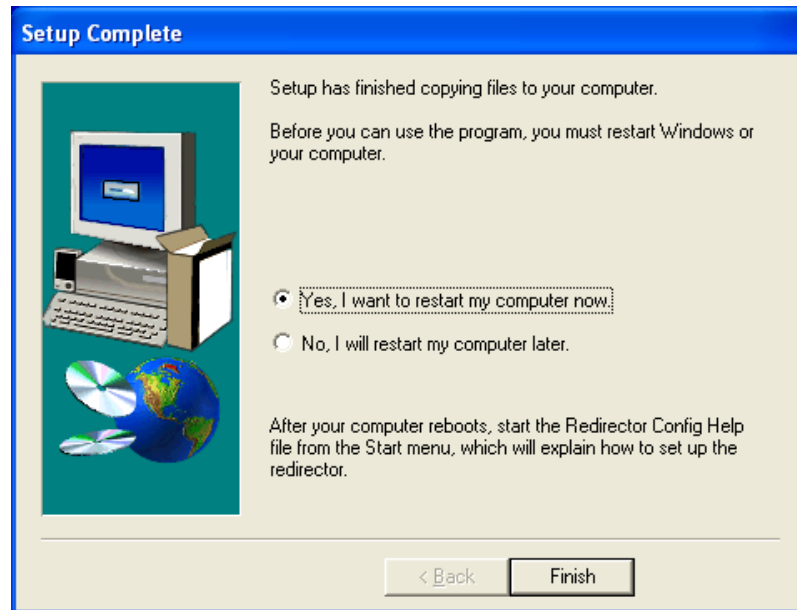

8. Click **Finish** to complete the installation and reboot your computer.

Note: After you complete the installation, we recommend you read the Read Me file to obtain the latest information about Com Port Redirector.

9. Click the **Start** button in the Windows Taskbar, point to **Programs**, point to **Lantronix Redirector**, and click **Configuration**. The Com Port Redirector Configuration window appears (see Figure 8-7).

Figure 8-7. Com Port Redirector Configuration Window

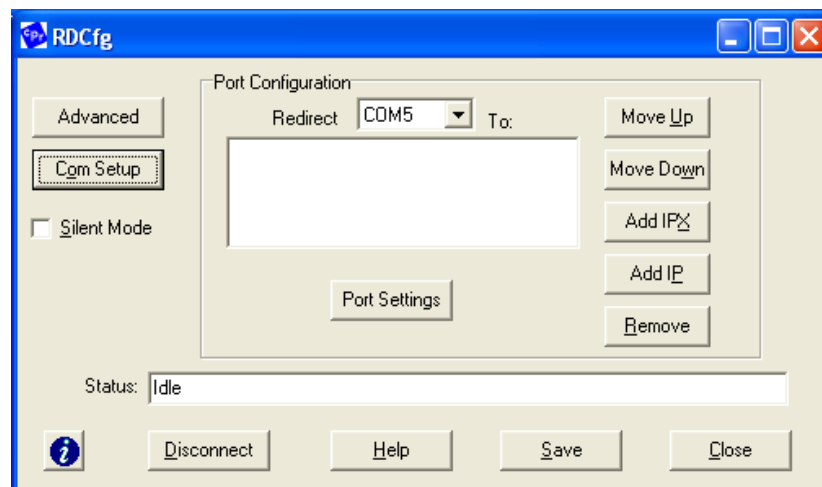

- Click the **Com Setup** button. A port Setup dialog box similar to the one in Figure 8-8 appears, with the first logical communications port checked.

The physical communication ports on the computer where Com Port Redirector is installed are displayed as gray and unavailable. In the picture below this is for Com 1. Your unavailable communication ports may vary from those in the picture below.

Figure 8-8. Port Setup Dialog Box

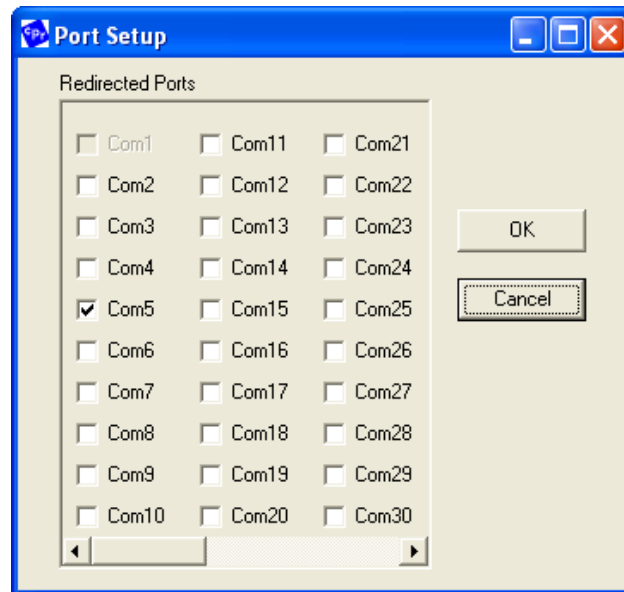

- Click all the logical ports to which the PC will be redirected. A checkmark appears next to each logical port selected. Each port selected will be available from the **Redirect To** drop-down list in the Com Port Redirector Configuration window (this procedure is described in the next chapter).
- To deselect a port, click it again to remove the checkmark next to it. Removing the checkmark indicates the port will not be available from the **Redirect To** drop-down list.
- When finished, click **OK**.

Note: After you use the Port Setup dialog box to add or remove com ports, reboot your computer.

8.3 Configuration

8.3.1 General Configuration Guidelines

Observe the following guidelines when preparing the gateway for use with Com Port Redirector.

- The gateway to which Com Port Redirector will connect must have an IP address.
- The PC running Com Port Redirector must have a good network connection to the gateway.
- If redirecting over a Wide Area Network (WAN), both the PC and the gateway must have a correct gateway address configured in their TCP/IP settings.
- All serial settings on the gateway must match the settings of the meter.
- Connect/Disconnect and Access Modes: The way the device server accepts a connection must be configured appropriately to accept a network connection from Com Port Redirector. Set the connect mode to C0 and the disconnect mode to 00.

8.3.2 General Com Port Redirector Usage Guidelines

Observe the following general guidelines when using Com Port Redirector:

- Do not run Com Port Redirector with other software that installs a virtual com port.
- Do not run Com Port Redirector with other Com Port Redirection software on the same PC.

8.3.3 Redirector Configuration

This section describes how to configure Com Port Redirector for use with PiiGAB 810 M-Bus gateway.

Choose IP address, Port number and baud rate to gateway before using the Com Port Redirector. This is easily made with the M-Bus Wizard if you can connect the computer to the local network or via the serial port on the gateway. The UDP box should not be checked. **All the traffic is only via TCP.** Alternately, this can be done via the Telnet or via the Hyper Terminal. The different configuration methods are described in chapter 4.4.

Figure 8-9. M-Bus 800 Family Setup Wizard

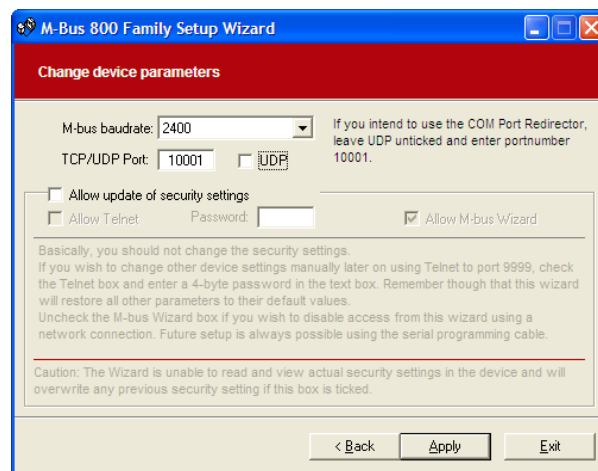

1. Click the **Start** button in the Windows Taskbar, point to **Programs**, point to **Lantronix Redirector**, and click **Configuration**. The Com Port Redirector Configuration window appears (see Figure 8-10).

Figure 8-10. Com Port Redirector Configuration Window

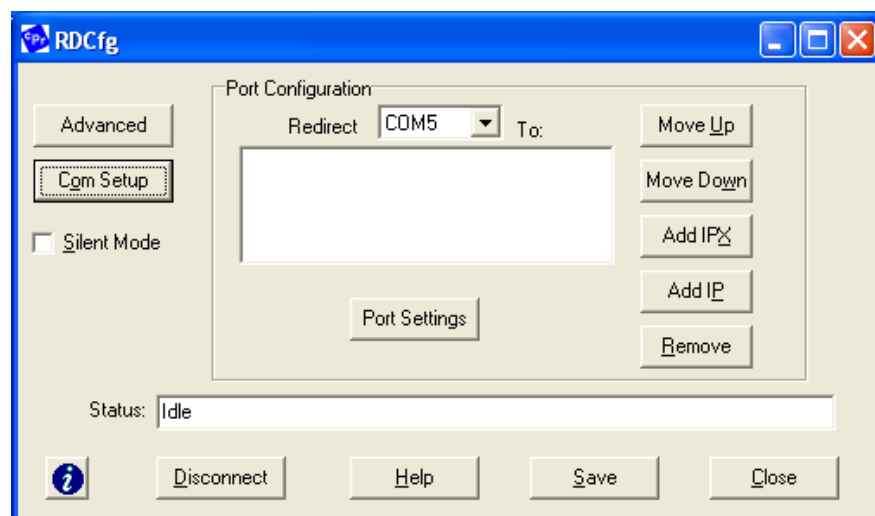

2. Using the **Redirect To** drop-down list at the top of the Com Port Redirector Configuration window, click a redirected com port.

810M.E.1.14

- Click the **Add IP** button. The IP Service Setup dialog box appears (see Figure 8-11).

Figure 8-11. IP Service Setup Dialog Box

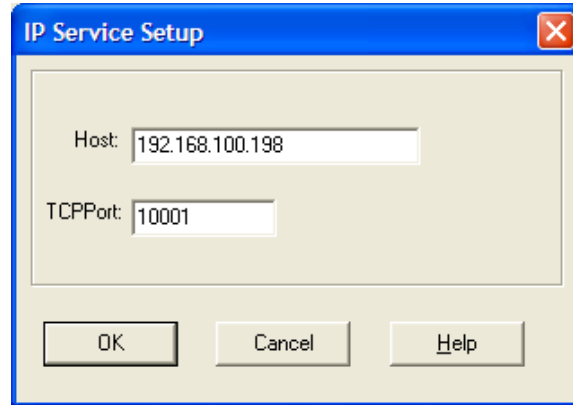

- In the **Host** field, enter the IP address of the gateway.
- In the **TCP Port** field, type the port number for example 10001.
- Click the **OK** button.
- Click the **Port Settings** button. The Port Settings dialog box appears.
- Check **Raw Mode**, **Timeout Reconnect** and **Server Reconnect** (see Figure 8-12). For more information refer to Table 4-1 in the original English document. Observe that Timeout Reconnect and Server Reconnect are not checked automatically at the installation. If you have interference on the net or if the net goes down these installations are necessary if an automatic restart should be made.

Figure 8-12. Port Settings Dialog Box

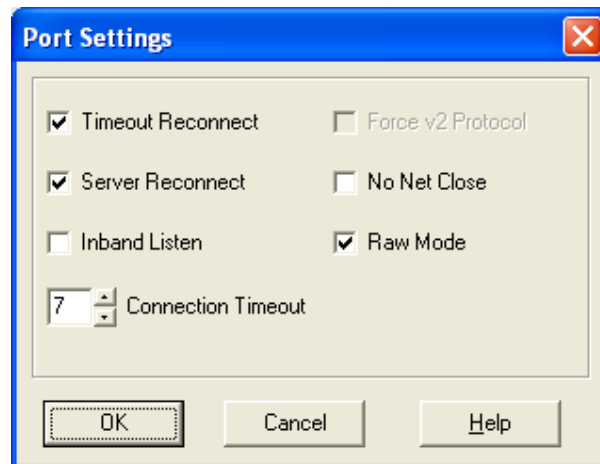

- Click **OK**.
- Click the **Save** button.

11. Click the **Close** button.
12. Proceed to Verifying Connectivity with the gateway.

8.3.4 Verifying Connectivity with the gateway

After configuring the Com Port Redirector and the gateway, use a terminal-emulation program such as HyperTerminal to verify connectivity from the Com Port Redirector to the gateway. To verify connectivity between Com Port Redirector and the gateway using HyperTerminal:

1. Click the **Start** button in the Windows Taskbar, point to **Programs**, point to **Accessories**, point to **Communications**, and click **HyperTerminal**.
2. Open a new session to the virtual com port configured to connect to the gateway.
3. When the HyperTerminal window opens, a pop-up window displays, *Attempting to connect to service*. If this message is replaced by:
 - *Successfully redirected to service*, the connection from the Com Port Redirector to the gateway was successful.
 - *Failed to connect to any service*, the connection failed. Ensure your settings are correct (refer to the appropriate configuration section in this chapter for setup procedures for you gateway).
4. To hide the pop-up window, check **Silent Mode** on the Com Port Redirector Configuration window.

Figure 8-13. Enabling Silent Mode

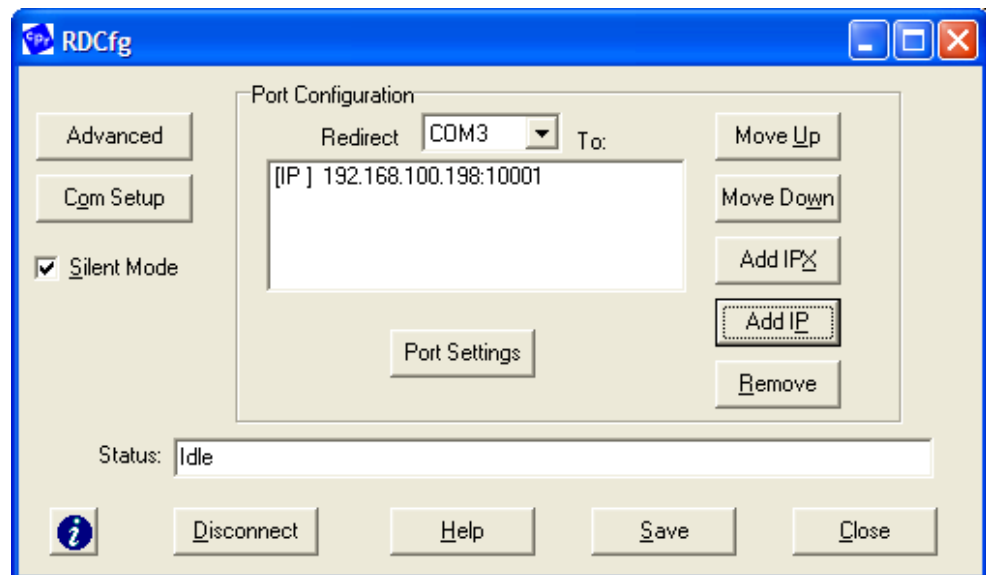

9 Appendix

9.1 Contacts

PiiGAB Processinformation

Anders Carlssons gata 7
417 55 Göteborg
Sweden

Phone + 46 31 55 99 77
www.piigab.com

Distributors

Please contact our distributors in respective countries:

Germany

Relay GmbH
Stettiner Str. 38
33106 Paderborn
Germany

Phone +49 5251 17670
www.relay.de

Norway

Autic Systems AS
Stoltenbergs gate 48
3110 Tønsberg
Norway

Phone +47 33 30 09 50
www.autic.no

Czech Republic

Papouch s.r.o.
Strasnicka 3164/1a
102 00 PRAGUE 10
Czech Republic

Phone +420 267 314 267
www.papouch.com

United Kingdom

Helping Buildings Think
Lutidine House
Newark Lane
Ripley, Surrey GU24 6BS

Phone +44 (0) 1483 270050
www.helpingbuildingsthink.com